

VF series

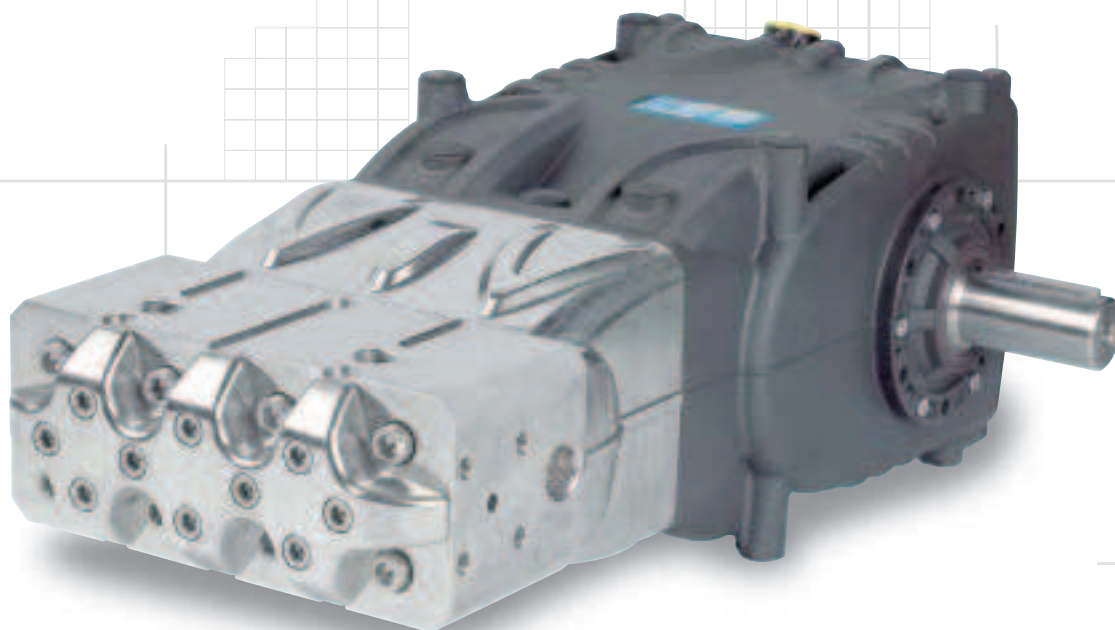

10 | 11

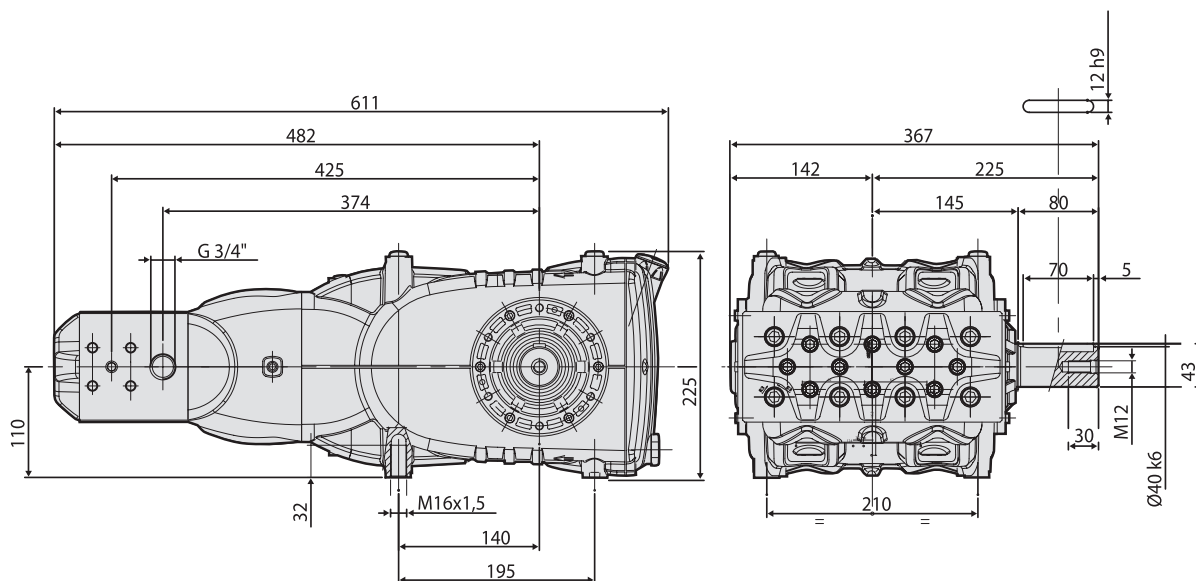

Tipo pompa Pump type	Portata Volume		Pressione Pressure		g/min r.p.m.	Potenza Power		Peso kg Weight kg	Dimensioni mm Dimensions mm
	l/min	US Gpm	bar	p.s.i.		hp	kW		
VF 12	12.7	3.4	1500	21750	750	50	37.0	62	611x367x225
	15.3	4.0	1200	17400	1000	48	35.3	62	611x367x225
VF 14	17.3	4.6	1100	15950	750	49	36.1	62	611x367x225
	23.0	6.1	800	11600	1000	48	35.3	62	611x367x225

Portate tecniche con rendimento volumetrico 100%
 Volumes are theoretical at 100% volumetric efficiency

VF accessories

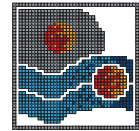

ACCESSORI BASE / BASIC ACCESSORIES

ALTRI ACCESSORI / OTHER ACCESSORIES

FILTRI FILTERS

■ F50/80

Acciaio inox
Stainless steel

Doppia cartuccia
Double cartridge

5/100
microns



10 bar 145 psi
40 l/min 10.5 gpm

MANOMETRI PRESSURE GAUGES

■ PG3



0-1000 bar
0-1600 bar

Attacco Gas 1/2"
Connection Gas 1/2"

■ TP60



0-1000 bar
0-1600 bar
0-2000 bar

Attacco Gas 1/2"
Connection Gas 1/2"
Trasduttore pressione
Pressure transmitter

VALVOLE A PEDALE FOOT VALVES

■ VP12

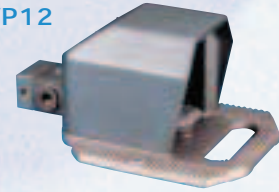

1500 bar 21750 psi
80 l/min 21 gpm

VALVOLE DI MASSIMA PRESSIONE MAX PRESSURE SETTING VALVES

■ SV12



1500 bar 21750 psi
100 l/min 26.4 gpm

Acciaio inox
Stainless steel

LANCE COMPLETE SPRAY GUNS

■ P12

Scarico libero
Dump gun



1500 bar 21750 psi
80 l/min 21 gpm

SLITTE TENDICINGHIE SLIDES

■ TC-G

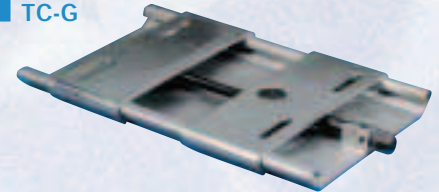

Per installazioni fino a 50 hp/37 kW
For installation up to 50 hp/37 kW

REGOLATORI DI PRESSIONE REGULATING VALVES

■ RV14



Acciaio inox
Stainless steel

1500 bar 21750 psi
100 l/min 26.4 gpm

UGELLI / NOZZLES

■ N3

Inserito in
zaffiro
Sapphire orifice



max. 1500 bar
max. 21750 psi

DISTRIBUTORI PNEUMATICI PNEUMATIC DUMPING VALVES

■ PN12

Acciaio inox
Stainless steel



1200 bar 17400 psi
80 l/min 21 gpm

■ PN14

Acciaio inox
Stainless steel

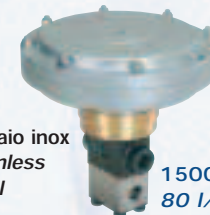

1500 bar 21750 psi
80 l/min 21 gpm

VALVOLE PNEUMATICHE PNEUMATICALLY OPERATED VALVES

■ PNRV14



Acciaio inox
Stainless steel

1500 bar 21750 psi
100 l/min 26.4 gpm

UGELLI ROTANTI ROTATING NOZZLES

■ ROTOMAX 750

Acciaio inox
Stainless steel



750 bar 11000 psi
50 l/min 13.2 gpm

■ ROTOMAX 1500

Titanio
Titanium



1500 bar 21750 psi
80 l/min 21 gpm